

PRODUCT DETAIL: VENICE-100 LOUVERS

ALUMINUM EXTRUSIONS 6063-T6 or 6061-T6 (per ASTM B-221)

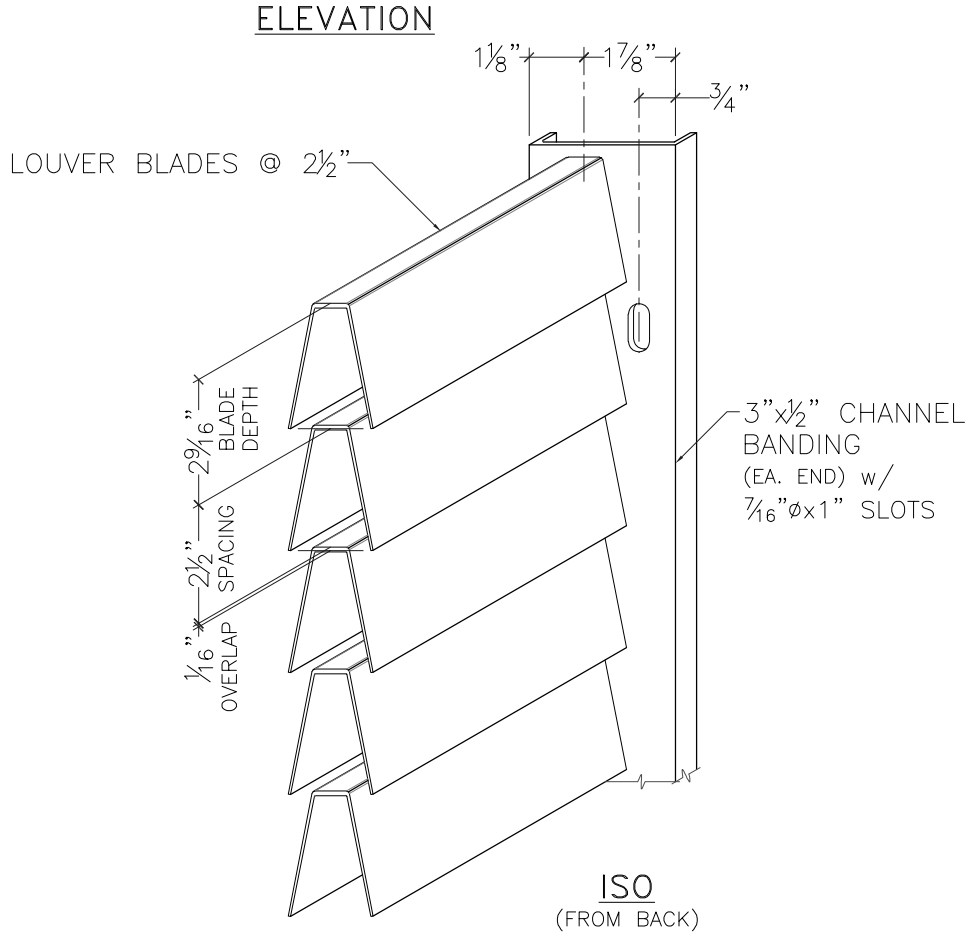
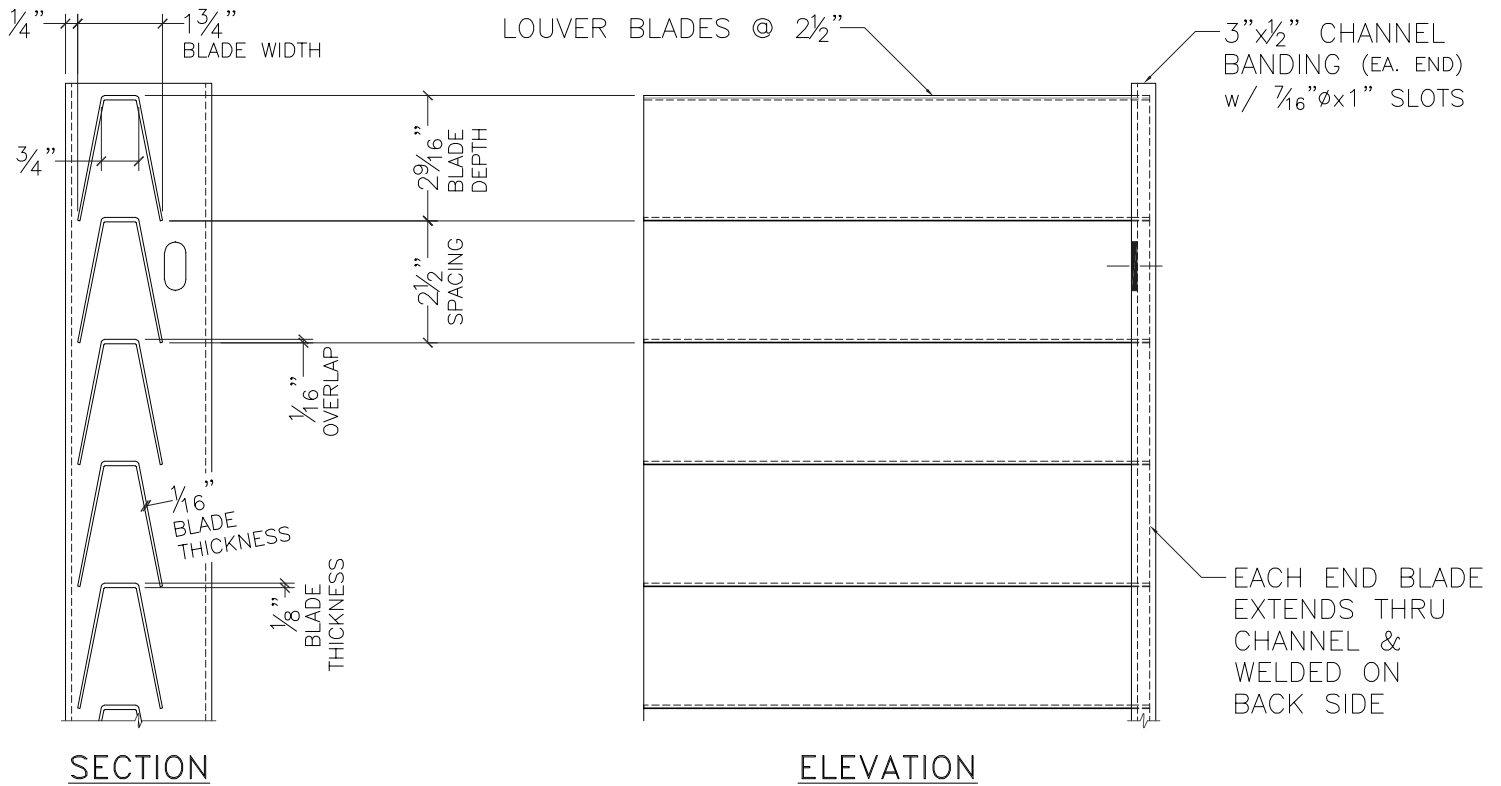

NOMMA
NATIONAL ORNAMENTAL & MISCELLANEOUS METALS ASSOCIATION

NAAMM METAL
ALL MANUFACTURING AND FABRICATING TOLERANCES & ALL WELDING SPECS. ARE IN COMPLIANCE WITH CURRENT N.A.A.M.M. METAL BAR GRATING MANUALS.

THIS DRAWING & THE INFO CONTAINED WITHIN ARE THE PROPERTY OF BARNETT-BATES CORP. IT IS NOT TO BE DUPLICATED OR USED FOR ANY PURPOSE NOT RELATED TO PRODUCTS FABRICATED BY BARNETT-BATES CORP.

SPECIFY GENUINE:

BARNETT BATES

Barnett-Bates Corp.
500 Mills Road
Joliet, IL 60433-2795

WWW.BARNETTBATES.COM

Phone: (815) 726-5223
Toll Free: (800) 541-3912
Fax: (815) 726-9210

PATTERN:

VENICE-100

(apx. *2.0# / S.F.)

*DOES NOT INCLUDE CHANNEL BANDING @ 0.563#/L.F.